

SECTION A-A SCALE 2:1

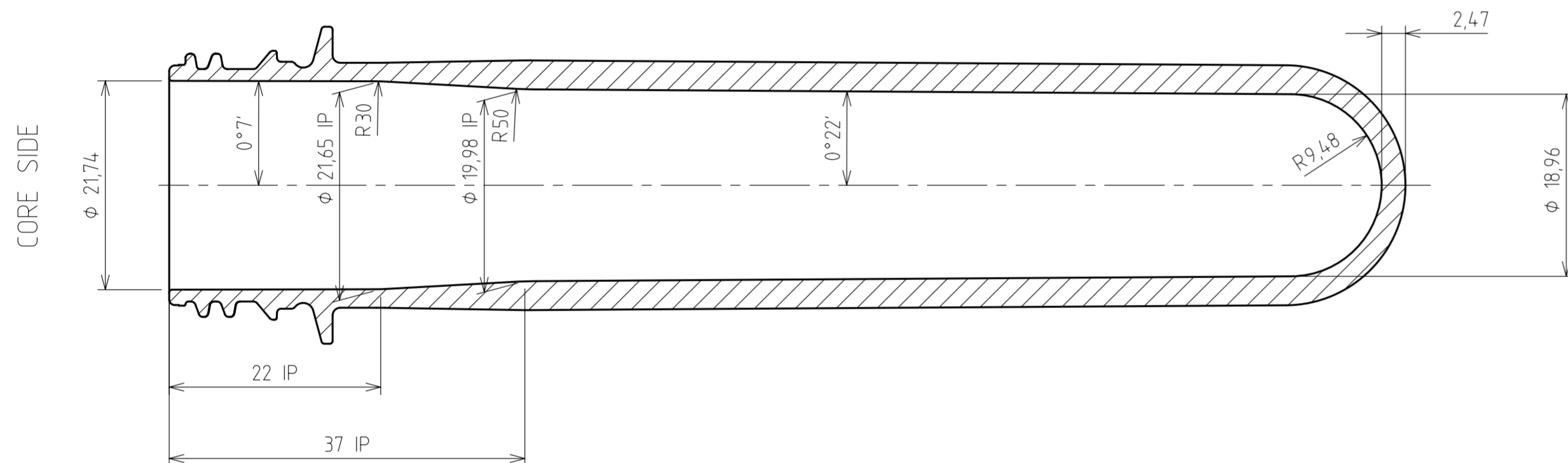

XX = Cavity Number
 RAPID OM XX
 Customer Logo Scale 2:1

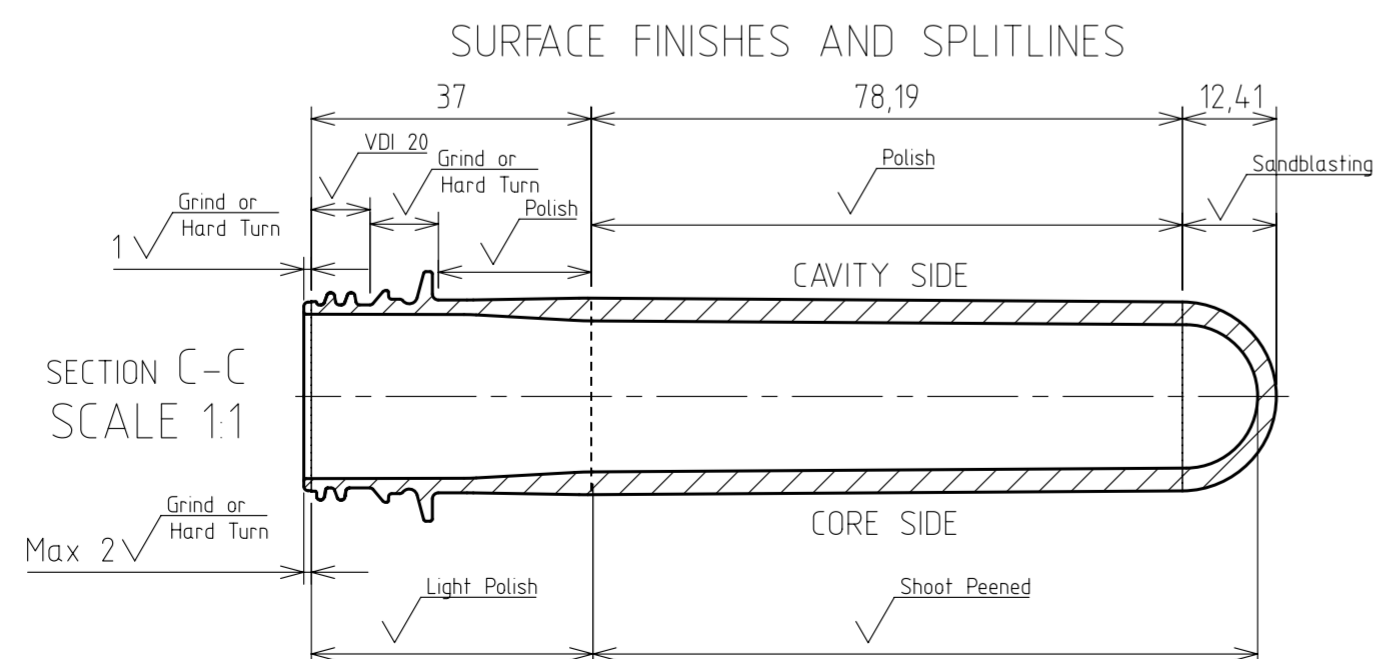
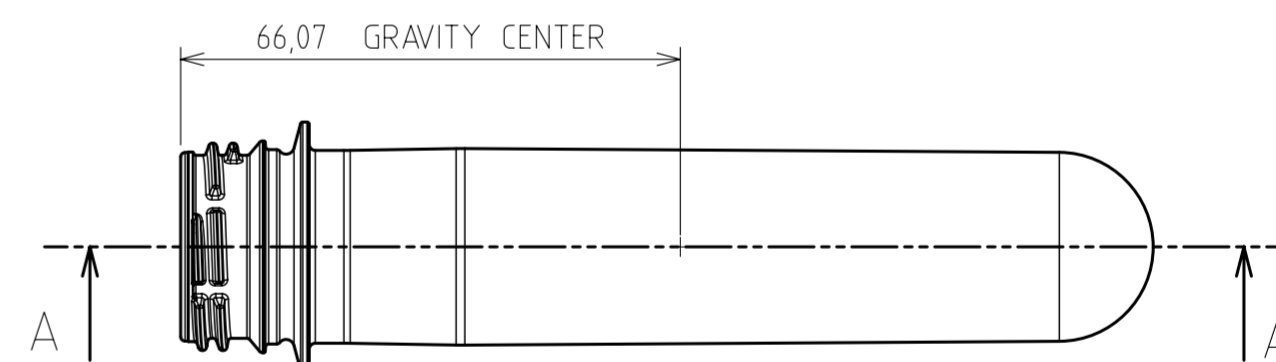
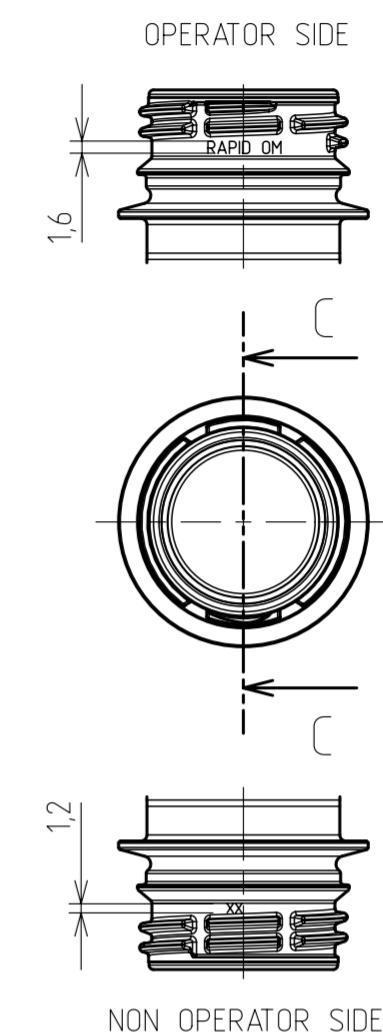

NOTES:

- 1) NECK FINISH WEIGHT 3,8g
- 2) THE FINISH COMPLY WITH DWG: N000051_86
- 3) DENSITY FOR WEIGHT CALCULATION 1,335g/cm³
- 4) IP = INTERSECTION POINT

DESCRIPTION: 28mm PCO 1881 NECK FINISH 33,7g PREFORM	SCALE: 1:1	NOTES:
	MATERIAL: PET	
	DATE: 21-Dec-2020 DRAWN: Dalla Libera, M. CHECKED: Manunta, M. APPROVED: Pizzinat, T.	
DRAWING N°: PN006856_00		

CONFIDENTIAL

SIPA